

A Role of Exhaust Gas Recirculation System of Vehicle for Minimization of Environmental Pollution

Mr. Pradeep V, R Yajnes

U. S. Ostwal Science, Arts and Commerce College, Mangalwad, Chittaurgarh, Rajasthan, India

Abstract: *Recently vehicle exhaust gas is major problem. During fuel combustion, the major expelled gasses of vehicles are carbon mono-oxide, particulate matter, carbon-di-oxide, hydro-carbons and nitrogen oxide. Nitrous oxide is very harmful to living things. The heavy duty vehicle engines are ON more time during transportation while it expels more nitrogen oxides. Exhaust Gas Recirculation (EGR) is a technology which recirculates the exhaust gasses and minimizes the percentage of harmful exhaust gasses of vehicle. Now only Low Pressure Exhaust Gas Recirculation (LPEGR) or High Pressure Exhaust Gas Recirculation (HPEGR) are implemented in costly engines only. If both Low LPEGR and HPEGR are implement then can be improve the harmful emissions.*

Keywords: Exhaust Gas, Vehicle, Exhaust Gas Recirculation

I. INTRODUCTION

Environmental consciousness and awareness about pollution from cars and commercial vehicles people have become more health conscious. The dealing with of exhaust gas is becoming more and more significant for people all over the world. The Perfect engine emissions regulation is technologically more complex but the exhaust gas treatments for harmful emissions are highly need of time. The environmental pollution taking place due to exhaust gas of transport vehicles on the road is day by day alarming. In order to improve the diesel engine performances, new technologies have been investigated. The major development in this situation, concerns the air path architecture for which a number of setups are: envisage, variable geometry turbines, low and high pressure EGR circuits. The parallel control structures have to be improved in order to address the new challenges [1].

II. DIESEL ENGINE AIR CIRCULATION PATH

The turbine is to converts exhaust gas energy into mechanical energy of the rotating turbo-shaft which rotates and drives the compressor. The compressor is used to increase the density of air and feed to the engine.

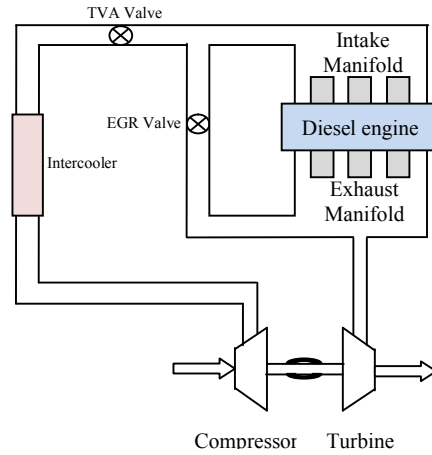

Figure 1 Diesel engine air circulation path

By varying the Throttle Valve Actuator (TVA) valve, it is possible to act on the mass flow rate through the engine intake manifold [2]. The diesel engine air path of is shown in figure 1.

III. AIR FUEL RATIO OF ENGINE

The air and fuel ratio is the most common reference term used for mixtures in internal combustion process of engines. The property of thermodynamic, composition of fuel and air and fuel combustion period decides the heat of combustion chamber. The air fuel ratio plays an important role in fuel combustion process. The ratio of mass of air to mass of fuel directly affect on efficiency of engine [3]. The mathematically represented equation of air fuel ratio is shown in equation (1)

$$\text{Air fuel ratio} = \frac{m_a}{m_f} \quad \text{--- (1)}$$

m_a = Mass of the air

m_f = Mass of the fuel

In India for the better engine performance the air fuel ratio is 14.7:1 (fourteen pound of air for every one pound of fuel) to 23:1 (twenty three pound of air for every one pound of fuel) [4].

IV. COMBUSTION CHAMBER ACTION OF FOUR STROKE ENGINE

The four stroke engine has four combustion chambers and the arrangement of the inlet-outlet valves are shown in figure 2. The process of valve is same for every revolution of shaft. Initially fuel and air mixture enters into the combustion chamber, after certain time inlet valve is going to off.

In that situation piston is pushed in upward direction and plug create spark, and help fuel to burn is shown in combustion chamber A. Near the end of fuel combustion process, the piston goes in the downward direction as shown in combustion chamber B. After completion of the combustion process, air fuel mixture turns in to gaseous form. Piston going upward direction pushes the gasses produced through outlet valve shown in combustion chamber C. In combustion chamber D the gas exit process is completed and exit valve gets closed. Once again inlet valve is opened and piston going to downward direction. The process is repeated for every revolution of the engine [5 -8].

V. FUEL COMBUSTION PROCESS

Temperature of the spread fuel is about 250⁰K is called ‘cold fuel’. The spread fuel when goes to middle of the combustion chamber, temperature of the fuel increases, and after the 1000⁰K of temperature the diesel combustion emitted. The first product generated 1000⁰K temperature is called PM (Particulate Matter). Soot zone temperature is formed due to less amount of oxygen and its temperature is about 1000⁰K. Figure 3 shows the CO₂ and H₂O generation region, the complete combustion process is operated in this region [6]. The high temperature region is called NO_x generation region and its temperature is 1500⁰K.

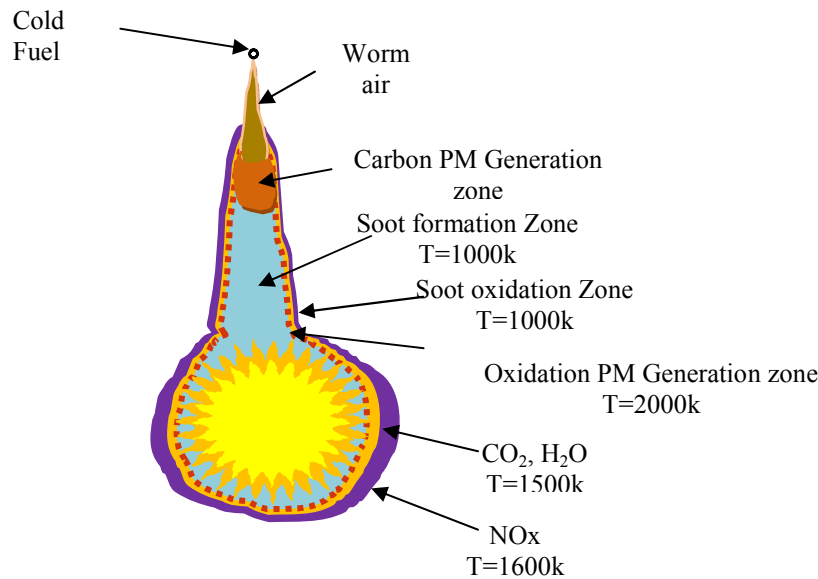
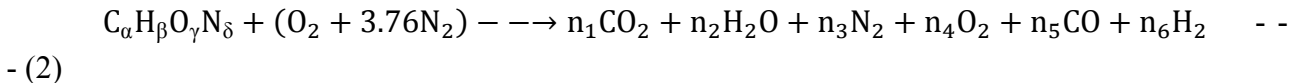

Figure 3 Diesel combustion process

VI. CHEMICAL REACTION OF FUEL COMBUSTION

Engine converts the chemical energy into mechanical energy. This energy is released in a series of combustions as fuel reacts with oxygen from the air [3]. Composition of the combustion was determined according to the solution given by Ferguson [4]. At low temperature and carbon to oxygen ratios less than one, the overall combustion reaction is modeled by equation (2).



According to the model of Olikara and Borman [9, 10], at high temperature combustion of fuel is represented by equation (1.6).

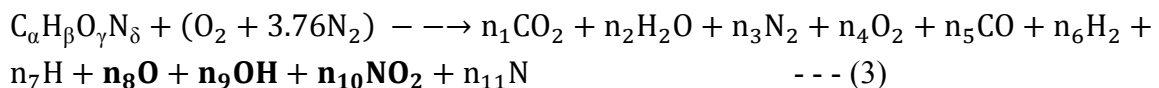

In high temperature combustion of fuel, extra generated exhaust gasses are displayed by bold letters. The complete combustion process for diesel fuel is modeled by (4)

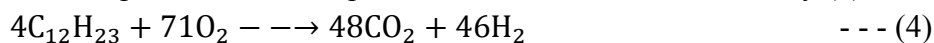

In complete combustion process only two products are generated namely carbon-di-oxide and water. This is impracticable in real time engine combustion process. It generates primary pollutants

gasses like Carbon Mono-oxide (CO), Particulate Matter (PM), Carbon-di-Oxide (CO₂), Hydro-Carbons (HC) and Nitrogen Oxide (NO_x)[11-13].

Among these, NO_x is highly harmful to the livings. In diesel or petrol engine the incomplete combustion process produces the various exhaust gases like CO, PM, and HC. When the temperature of combustion chamber exceeds the maximum limit about 1450⁰C, the NO_x (Nitrous Oxide) gases are produced [14]. The mixture has lower amount of oxygen for combustion that causes the effective air fuel ratio. This effective reduction in air and fuel ratio affects the exhaust emissions substantially. By mixing the exhaust gases with intake air enhances specific heat of intake mixture, which results in the reduction of gas flow temperature. The lower amount of oxygen is passed to the combustion chamber through intake manifold, then after fuel combustion exhaust flame temperature as well as NO_x generation rate is reduces. The combustion chamber temperature depends on available amount of oxygen level [5, 14]. The NO_x is produced primarily due to the oxidation of the atmospheric nitrogen during the fuel combustion process at higher temperatures. The NO_x emission control technique is currently advance development areas included in the engine control system [15].

VII. IDEAL EXHAUST GASSES PERCENTAGE

In diesel engine converts chemical energy containing in the fuel into mechanical power. During ideal combustion process, gas contents produced in percentage are shown in figure 4. Percentage of nitrogen gasses is greater during higher temperature as it reacts more with oxygen and generates NO_x.

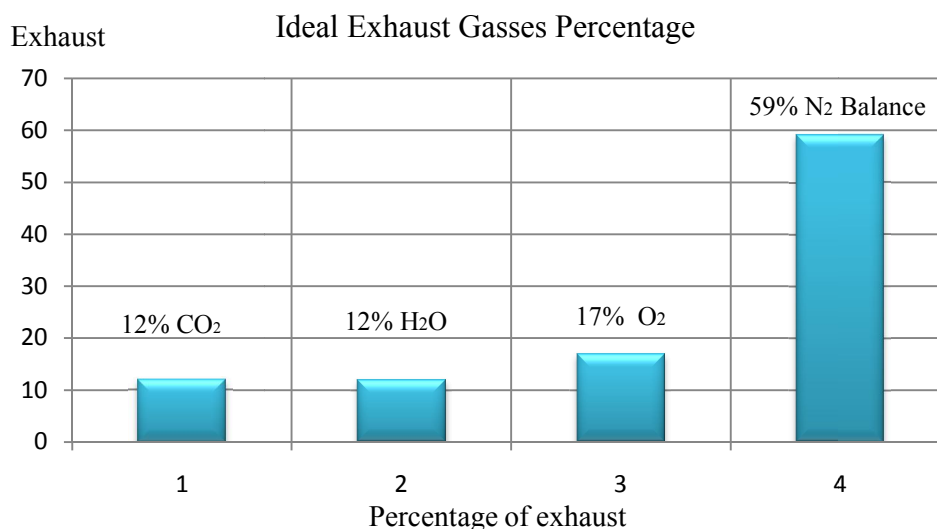

Figure 4 Ideal exhaust gas percentages in diesel fuel

The concentrations of exhaust gas depend on the engine load, engine speed. In 100 percent fuel combustion generate only two gasses named as carbon-di-oxide and water only [17]. But in diesel engine the content of CO₂ and NO_x increasing, that of O₂ and H₂O decreasing with increasing engine load.

VIII. EGR System

EGR system is one of the solutions for reduction of NO_x gasses because it controls the temperature of combustion chamber on engine and keep it bellow limit. The major exhaust gases are carbon dioxide, nitrogen oxide, hydrocarbons and the mixture bears higher specific heat compared to atmospheric air. The Re-circulated exhaust gas mixed with fresh air is enters the combustion chamber with carbon dioxide and water vapor present in engine exhaust.

Exhaust gas recirculation (EGR) system is an emission control technology allowing drop significant in NO_x emission to from modern types of diesel engines, from light-duty engines through medium to heavy duty engines. The rate of Nitrogen Oxide emission increases with vehicle speed, and as compared to petrol engine. The Diesel engine combustion generates large amounts of NO_x because of the greater flame temperature in the presence of abundant nitrogen and oxygen [15 - 18]. However, the advantages of diesel engine vehicles over petrol engine vehicles like good fuel economy, higher power and lower maintenance cost has brought the status in the society. Diesel engine is good power equipments, high capable of torque movement and more economically in electricity generation than any other engine. With load of engine is an increase similarly the percentage of EGR gasses increases but the affecting of the engine [5]. Purpose of the EGR system is to precisely regulate EGR flow under different operating conditions and improve the engine exhaust gas performance. Precise amount of exhaust gas which is intake manifold varies significantly as engine load changes. A certain time engine temperature is imbalance but the EGR system operates on very fine line between good NO_x controls [14]. The diesel engines have high thermal efficiencies, high compression ratio and lean fuel burn operation. For high temperature fuel combustion process engine gives less thermal efficiency [19]. Percentage of EGR depends on loads of the engine, temperature of the combustion chamber, emission characteristics of the engine and compression ratio. A single cylinder variable compression diesel engine has different compression ratios [19, 20].

In traditional EGR system depends on two factors such as engine load and exhaust gas flame temperature. In environmental conscious Nissan industry was first used EGR for their heavy duty engine. The single valve controlled EGR technology adopted for special motor cars. Consideration of engine efficiency High Pressure Exhaust Gas (HPEGR) technology was developing. The path of air is outlet of combustion chamber exhaust gas is applied directly to inlet valve of engine; in this process compressor, turbine and EGR cooler is not a part of EGR [21]. This system had problem for its valve open too much, which causes hesitation; more amount of gas was re-circulated. Due to this hesitation during repairing of engine many times it is disconnected. Then 'unplugged EGR' was developed but it had come in engine ping drivability complaint, it had been solved from after some days. The closed loop computer were in place. The EGR flow was then more carefully controlled with dual diaphragm and backpressure EGR valves [21]. Then concept of Low Pressure Exhaust Gas Recirculation (LPEGR) was introduced. As consideration of EGR pressure the Cool EGR system is also classified into two type's High Pressure EGR (HPEGR) and Low Pressure EGR (LPEGR) system.

IX. COMMENT

Day by day, the numbers of vehicles are increases while due to fuel combustion of vehicle the expelled gasses rate are increases. The major expelled gasses of vehicle are carbon mono-oxide, particulate matter, carbon-di-oxide, hydro-carbons and nitrogen oxide. Out of these gasses, nitrogen oxide is very harmful to living things. It is generated during high temperature fuel combustion only. Thus we should avoid the high temperature fuel combustion. The heavy duty vehicle exhausts more gasses because these vehicles are on road more times for transport. We are not removing the pollutant gasses but it mix in environment.

Using EGR technology the some amount of expelled gasses are given to the inputs and reduces the percentage of exhaust gasses. There are two types of EGRs such as LPEGR and high pressure HPEGR. In HPEGR the path of air is, outlet of combustion chamber exhaust gas is applied directly to inlet valve of engine; in this process compressor, turbine and EGR cooler is not a part of EGR. In this EGR system, high temperature vehicle exhaust is re-circulated. HPEGR helps to enhance the combustion chamber temperature while it gives better performance at beginning time of engine. However, in LPEGR compressor, combustion chamber and turbine is a part of EGR system. The temperature of exhaust air of LPEGR is less than HPEGR. Due to LPEGR combustion chamber, temperature enhancing rate is less wile it gives better performance when engine ON time is more than one hour. If both HPEGR and LPEGR will implemented in engine then we can maintain the combustion chamber temperature, as improve the fuel combustion temperature as well as harmful exhaust of vehicle.

REFERENCES

- [1]. Le Sollicec, G., Corde, G., Hayat, O. , Jabeur, C. and Calendini, P.O. “Low pressure EGR control for a turbocharged diesel HCCI engine” Control Applications, (CCA) & Intelligent Control, (ISIC), IEEE pp. 346 – 351, 2009.
- [2]. S. Simani and M. Bonfè “Fuzzy Modelling and Control of the Air System of a Diesel Engine” Advances in Fuzzy Systems, 2009.
- [3]. Jaffar Hussain, K. Palaniradja, N. Alagumurthi and R. Manimaran “Effect of Exhaust Gas Recirculation (EGR) on Performance and Emission characteristics of a Three Cylinder Direct Injection Compression Ignition Engine” Alexandria Engineering Journal, pp. 241-247, November 2012.
- [4]. Jan-Ola Olsson, Per Tunestål, Jonas Ulfvik and Bengt Johansson “The Effect of Cooled EGR on Emissions and Performance of a Turbocharged HCCI Engine” Lund Institute of Technology, 2003.
- [5]. Alain Maiboom, Xavier Tauzia “NOx and PM emissions reduction on an automotive HSDI Diesel engine with water-in-diesel emulsion and EGR: An experimental study” Fuel, vol. 90, Issue 11, Pages 3179–3192, November 2021.
- [6]. Putting some numbers on the diesel engine” 8 feb 2013, <http://chembloggreen1.wordpress.com/2013/02/08/putting-some-numbers-on-the-diesel-engine-2/> March 1, 2022.

- [7]. Ferguson CR. Internal combustion engines-applied thermosciences. John Wiley & Sons; 1986.
- [8]. Market overview on exhaust gas treatment solutions for diesel engines in commercial vehicles for meeting current and upcoming emission legislation in the european union, F2006SC09, Steffens, Dirk VDI, Germany.
- [9]. Xing-Cai Lu, Wei Chen and Zhen Huang “A fundamental study on the control of the HCCI combustion and emissions by fuel design concept combined with controllable EGR. Part 1. The basic characteristics of HCCI combustion” Fuel, vol. 84, Issue 9, pp.1074–1083, June 2005.
- [10]. S. Ghosh and D. Dutta “Performance and emission parameters analysis of gasoline engine with EGR” International Journal of Engineering Research and Development, vol. 4, Issue 10, PP. 08-12 , November 2012.
- [11]. Emission Sub System- Exhaust Gas Recirculation, Toyota Motors sales, USA.
- [12]. Anna G. Stefanopoulou and Ilya Kolmanovsky “Analysis and Control of Transient Torque Response in Engines with Internal Exhaust Gas Recirculation” IEEE Transactions on Control Systems Technology, vol. 7, no. 5, pp.555-566, September 1999.
- [13]. Edwin Lughofer, Vicente Macián, Carlos Guardiola and Erich Peter Klement “Identifying static and dynamic prediction models for NOx emissions with evolving fuzzy systems” Applied Soft Computing, vol. 11, Issue 2, pp. 2487–2500, March 2011.
- [14]. M.A. Ceviz and I. Kaymaz “Temperature and air–fuel ratio dependent specific heat ratio functions for lean burned and unburned mixture” Energy Conversion and Management, vol. 46, Issues 15–16, pp. 2387–2404, September 2005.
- [15]. Exhaust Gas Recirculation and control with pierburg component, pierburg, http://www.kspg.com/fileadmin/media/Broschueren/Produktbroschueren/Pierburg/Schadstoffreduzierung/pb_kombi_agr_EN_low.pdf february 08, 2022.
- [16]. Ming Zhenga, Graham T. Reader and J. Gary Hawley “Diesel engine exhaust gas recirculation—a review on advanced and novel concepts” Energy Conversion and Management, vol. 45, Issue 6, pp. 883–900, April 2004.
- [17]. N. Ravi Kumar, Y. M. C. Sekhar and S. Adinarayana “Effects of Compression Ratio and EGR on Performance, Combustion and Emissions of Di Injection Diesel Engine” International Journal of Applied Science and Engineering vol.11, Issue 1, pp.41-51, 2013.
- [18]. Underhood Service “Diagnosing Exhaust Gas Recirculation (EGR)”, July 18, 2013, web: http://www.underhoodservice.com/Article/116007/diagnosing_exhaust_gas_recirculation_egr.aspx February 29, 2022.
- [19]. Mohamed Y.E. Selim “Effect of exhaust gas recirculation on some combustion characteristics of dual fuel engine” Energy Conversion and Management, vol. 44, Issue 5, pp. 707–721, March 2003.
- [20]. M. H. Salah, T. H. Mitchell, J. R. Wagner, Ph.D., PE, and D. M. Dawson, Ph.D. “Multiple Cooling Loops in Advanced Vehicle Thermal Management Systems” For submission to IEEE/ASME Transactions on Mechatronics, June 2007.

- [21]. Buomsik Shina, Youngsoo Choa, Daeha Hanb, Soonho Songa and Kwang Min Chun “Hydrogen effects on NO_x emissions and brake thermal efficiency in a diesel engine under low-temperature and heavy-EGR conditions” International Journal of Hydrogen Energy, vol. 36, Issue 10, pp.6281–6291, May 2011.
- [22]. H.E. Saleh “Experimental study on diesel engine nitrogen oxide reduction running with jojoba methyl ester by exhaust gas recirculation” Fuel, vol. 88, Issue 8, pp.1357–1364, August 2009.
- [23]. “Differences Two stroke N Four Stroke Engine” May 2, 2021. <http://muzakstudyzone.blogspot.in/2012/12/differences-two-stroke-n-four-stroke.html> May 2, 2014.
- [24]. Kyungtaek Lee, Taesoo Kim, Hyoseok Cha, Soonho Song and Kwang Min Chun “Generating efficiency and NO_xemissions of a gas engine generator fueled with a biogasehydrogen blend and using an exhaust gas recirculation system” International Journal of Hydrogen Energy, vol. 35, Issue 11, pp. 5723–5730, June 2020.
- [25]. Jungsoo Park and Kyo Seung Lee “Optimization of Diesel Engine with Dual-Loop EGR by Using DOE Method” Diesel Engine – Combustion, Emissions and Condition Monitoring chapter 6 pp. 146-160.